

# Pre-primary/Preprimêr: Week 21 & 22

5-6 years/ 5-6 jaar

English / Afrikaans

Draw a picture of your community. /  
Teken 'n prent van jou gemeenskap.

## My Community / My Gemeenskap

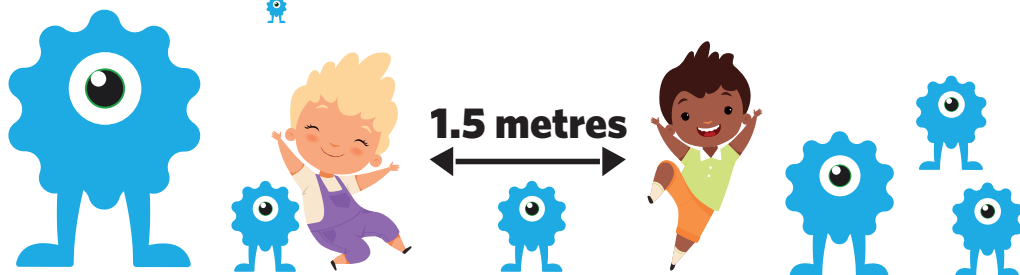

These numbers indicate which day you can complete each worksheet! But if you want to, you can work ahead and do the rest as well.

**This publication is a collaboration between the Ministry of Education, Arts and Culture and Namibia Media Holdings. This publication is sponsored by the Ministry.**

**Copyright © Ministry of Education, Arts and Culture.** All parts of this publication cannot be reproduced, stored in a retrieval system or transmitted in any form or by any means, electronic, mechanical, photocopying, recording or otherwise without prior permission of the Ministry of Education, Arts and Culture or the Publisher.

Production by: Namibia Media Holdings **NMH** NAMIBIA MEDIA HOLDINGS

Printing: Newsprint Namibia **newsprint** NAMIBIA

**The Ministry of Education, Arts and Culture**  
www.moe.gov.na



# My Community / My gemeenskap

Colour the different types of transport. /  
Kleur die verskillende tipe vervoer in.

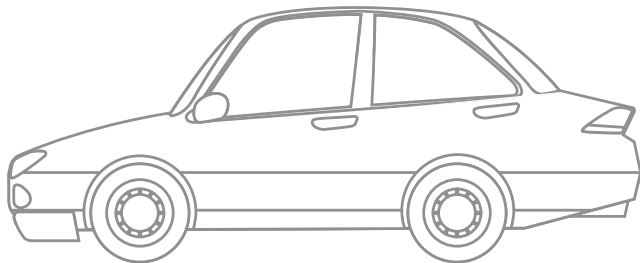
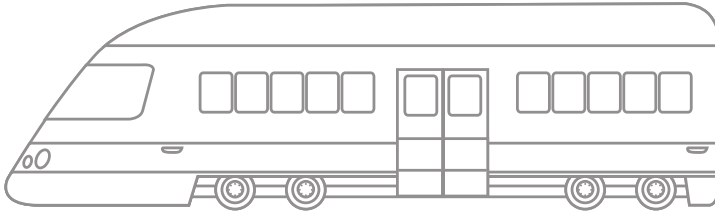
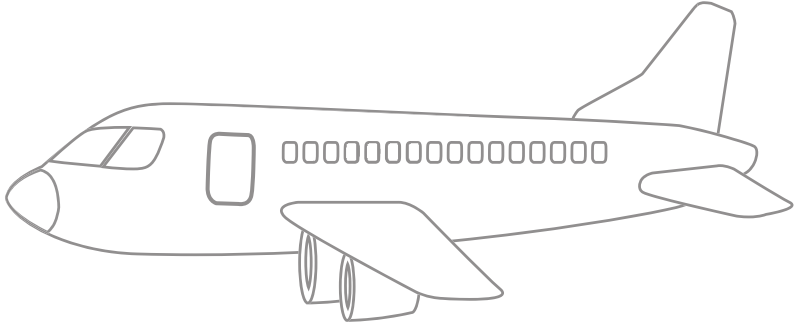
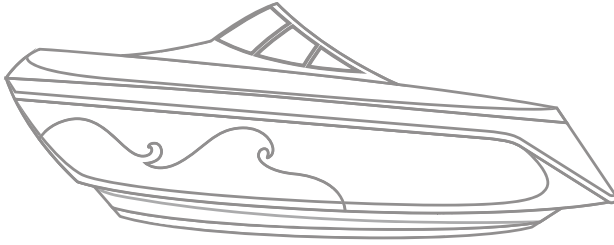

Draw any local transport. / Teken enige plaaslike vervoer.

Week 21

Preprimary





Draw where the seatbelt should be. Discuss with your teacher or parent why it is important to wear your seatbelt. /

Teken die veiligheids gordel op die regte plek. Praat met jou juffrou of ouers oor hoekom dit belangrik is om 'n veiligheids gordel te dra.



Colour in all the healthy food. / Kleur al die gesonde kos in.

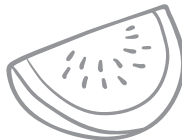
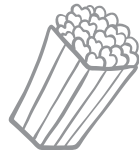
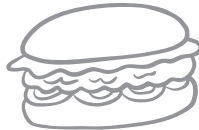
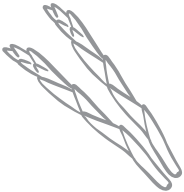
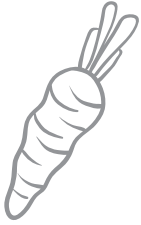

Week 21

Preprimary



Draw your favourite food. / Teken jou gunsteling tipe kos.

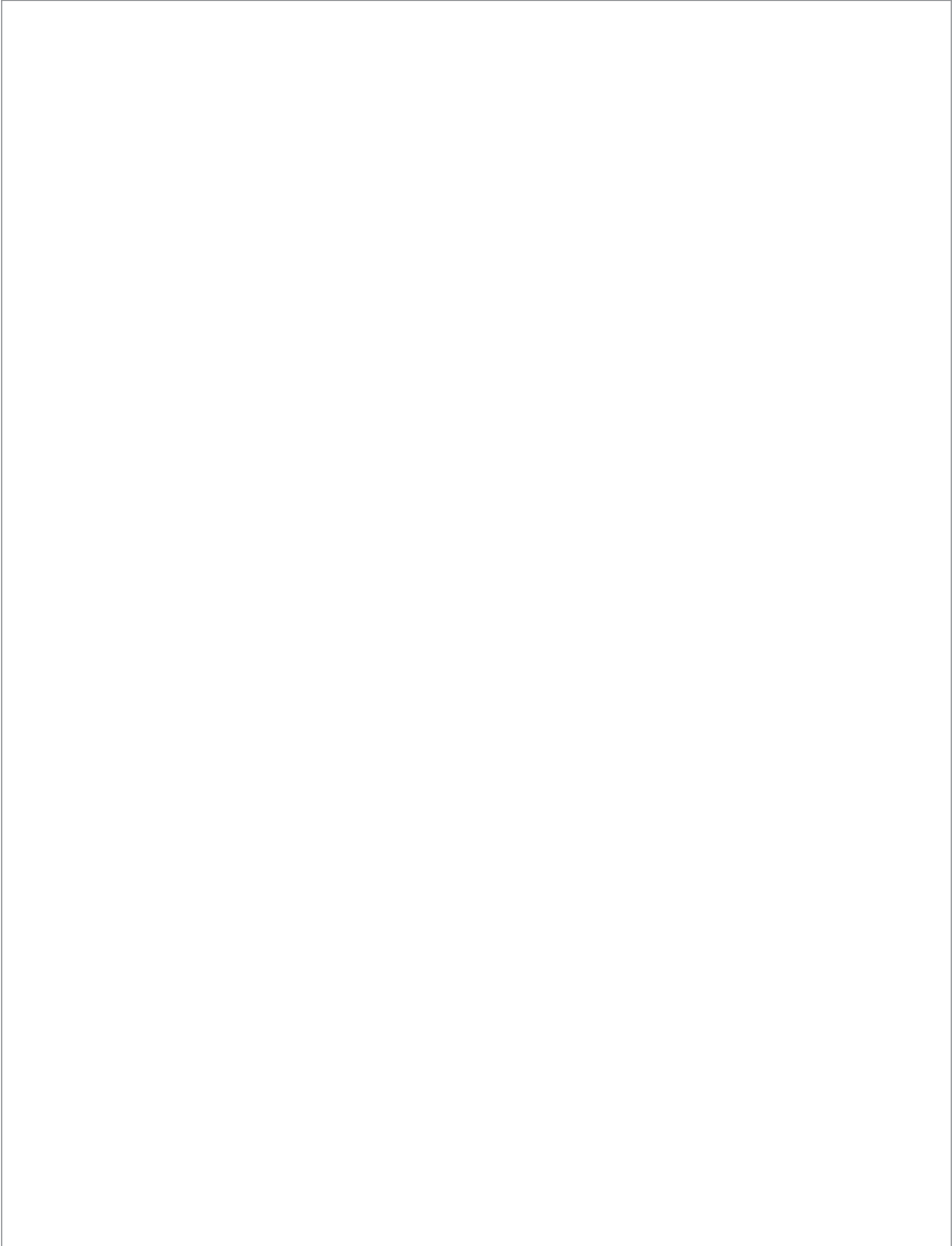

Draw the occupation you want to become one day./  
Teken die beroep wat jy eendag wil word.

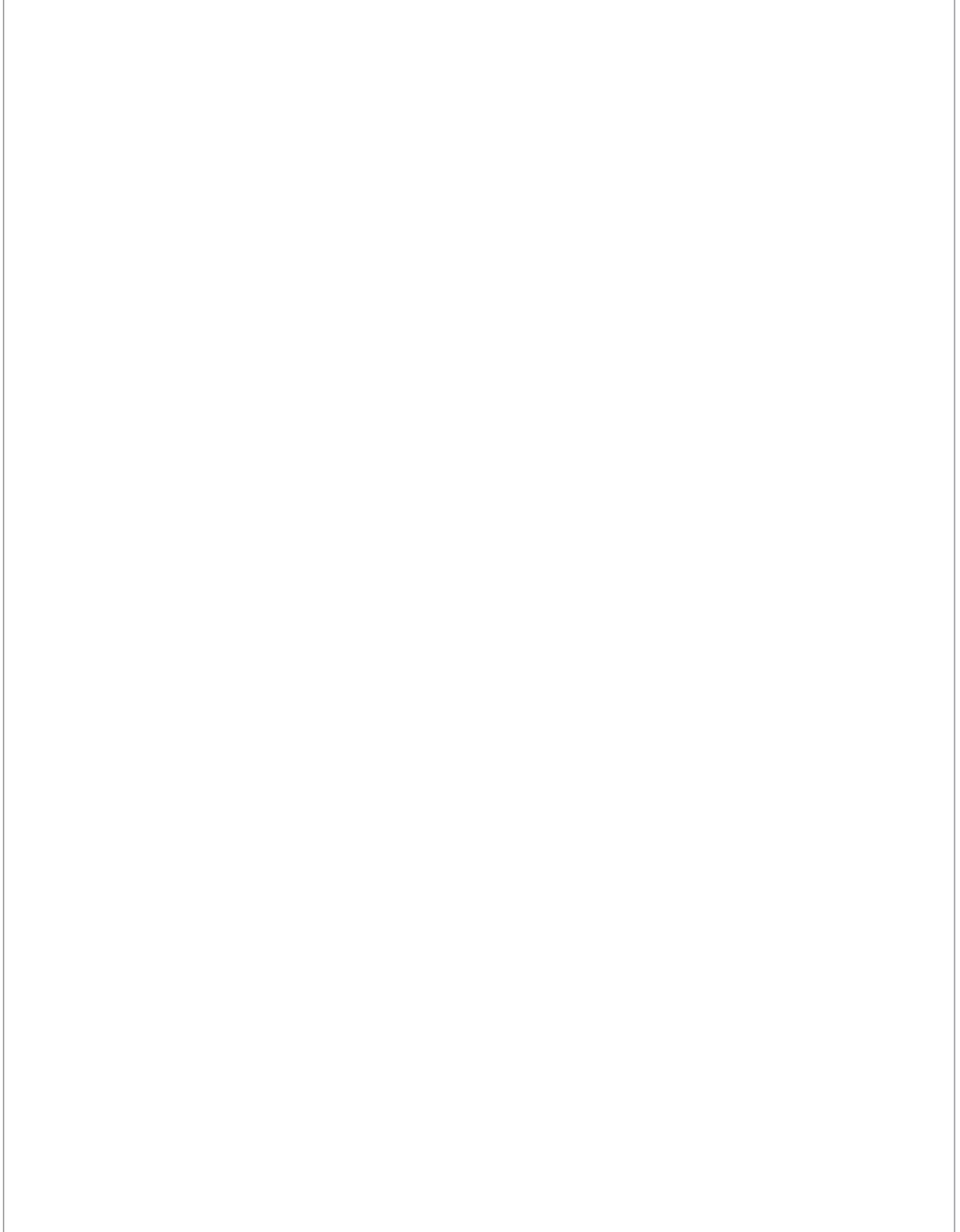

Week 21

Preprimary

Write number 6. / Skryf nommer 6.

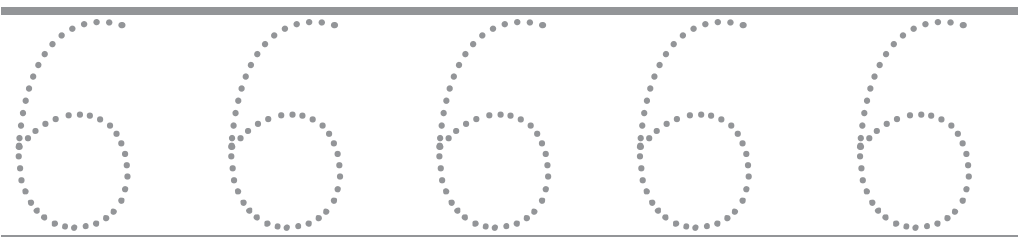
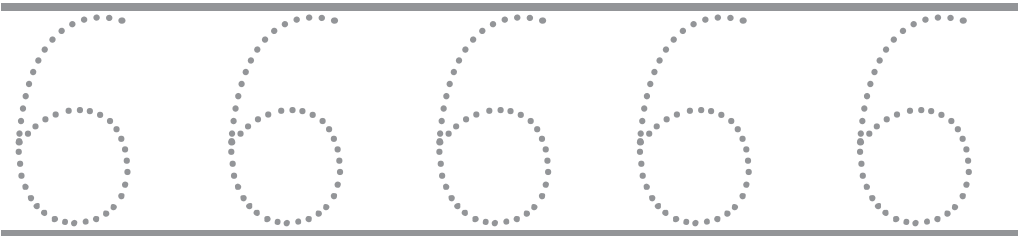
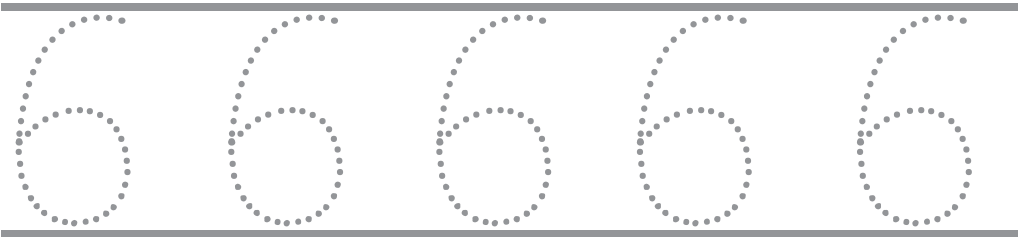
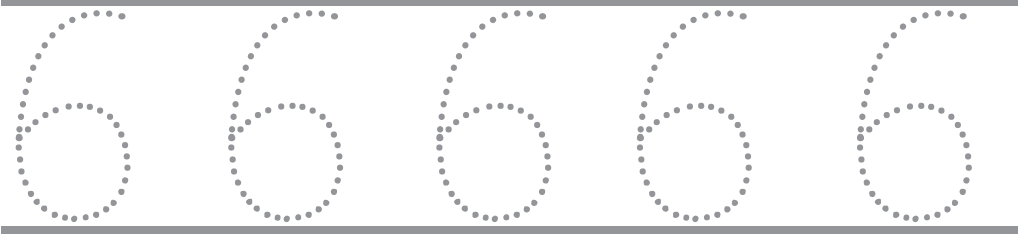

Week 21

Preprimary

Match each item to the correct group. /  
Verbind elke item met die regte groep.

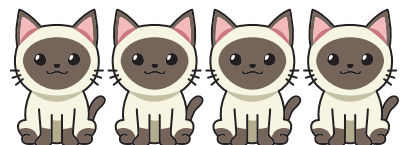
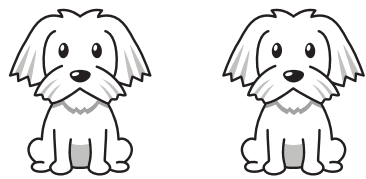
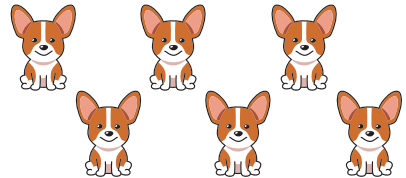
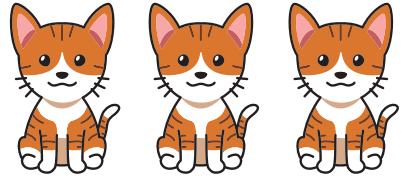
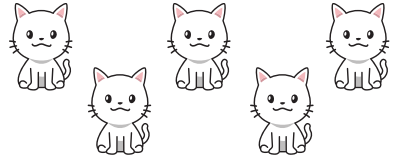

Week 21

Preprimary

String beads in the given pattern. /  
Rangskik die krale in die gegewe patroon.

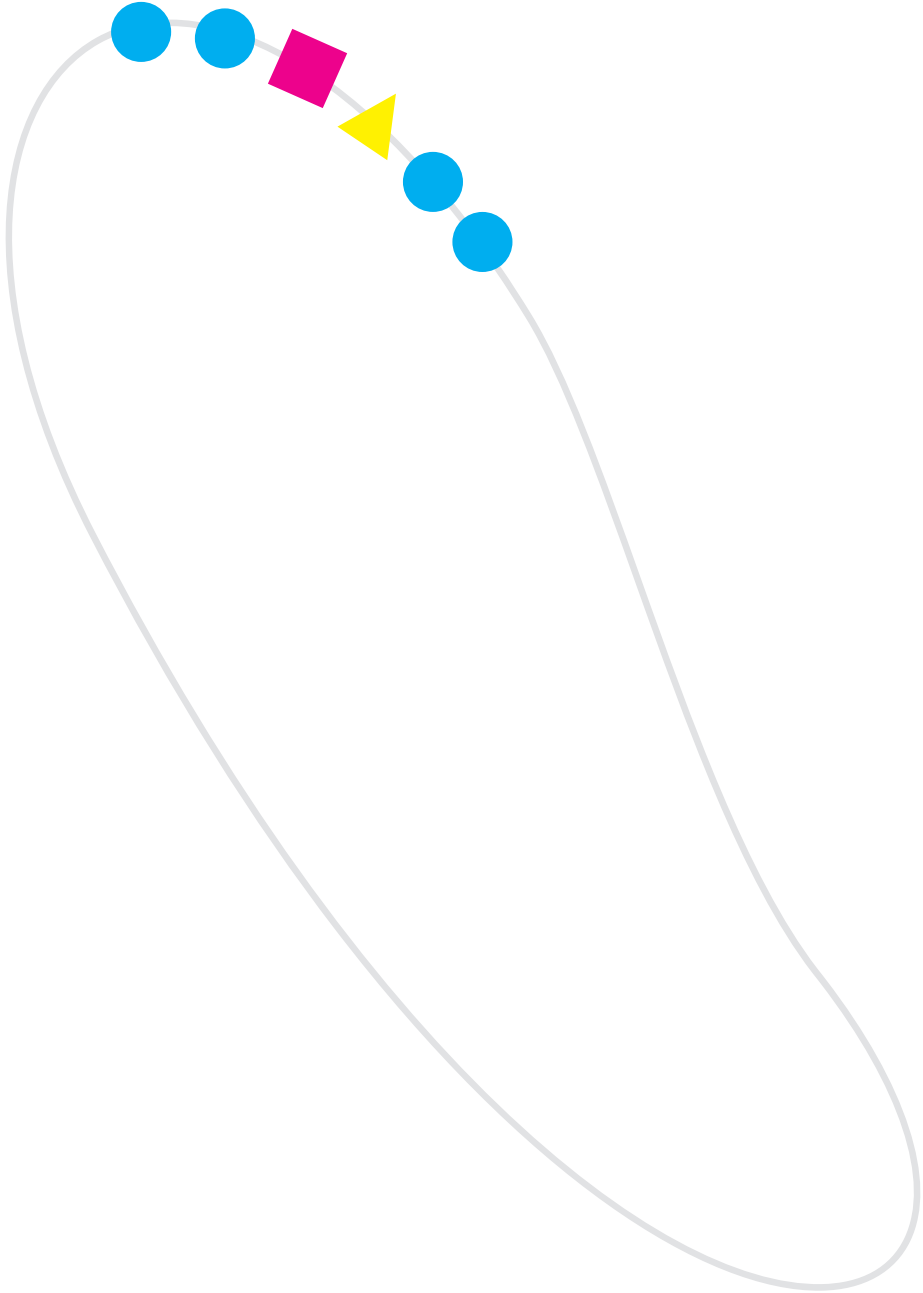

Draw and colour the bottles to show full, half and empty. /  
Teken en kleur in bottels om vol, half en leeg aan te wys.

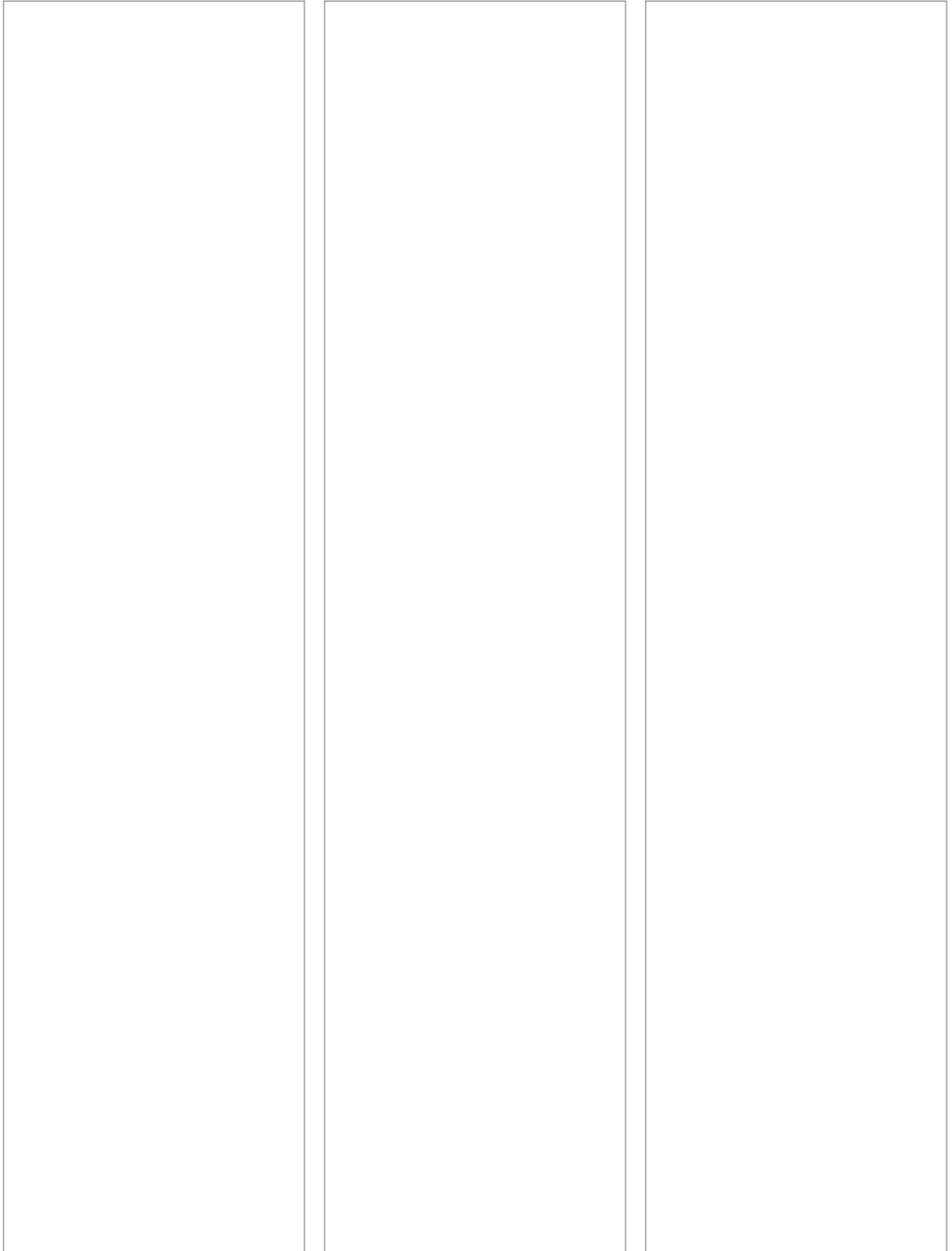

Week 21

Preprimary



Circle all the names with same beginning sound. /  
Omkring al die name met dieselfde begin klank.



Silas



Susan



Sam



Anna

Week 21

Preprimary

Circle all the number sixes. / Omkring al die nommer sesse.

2 4 1 3 6 4  
 2 6 3 5 2 1  
 4 4 6 3 6 6  
 5 6 5 6 2 4  
 1 2 5 3 6 1  
 6 1 6 4 1 3  
 3 4 2 6 5 6



Identify all brown shoes and circle them. /  
 Identifiseer alle skoene wat bruin is en omkring dit.

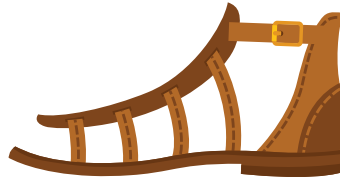

Week 21

Preprimary

Colour the first and the last persons in the row. /  
Kleur die eerste en laaste mense in die ry.

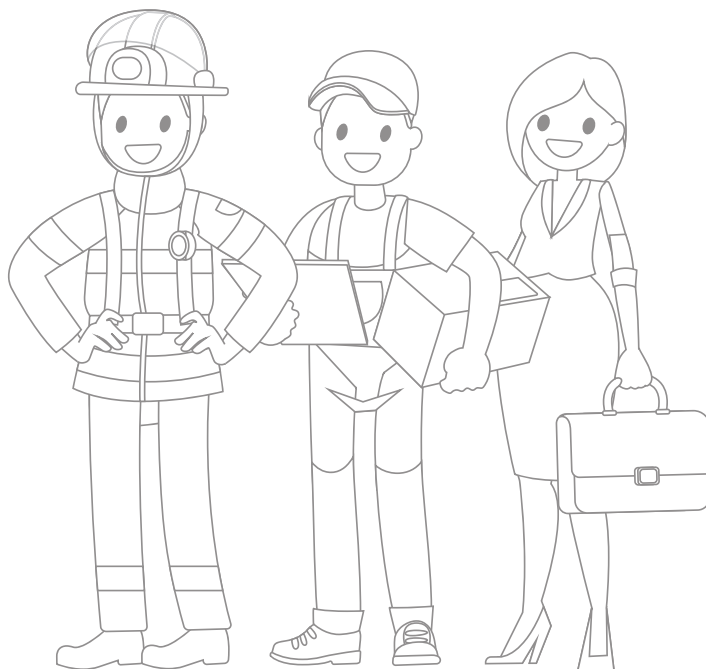

Colour all short rulers with a brown colour. /  
Kleur al die kort liniale in met bruin.

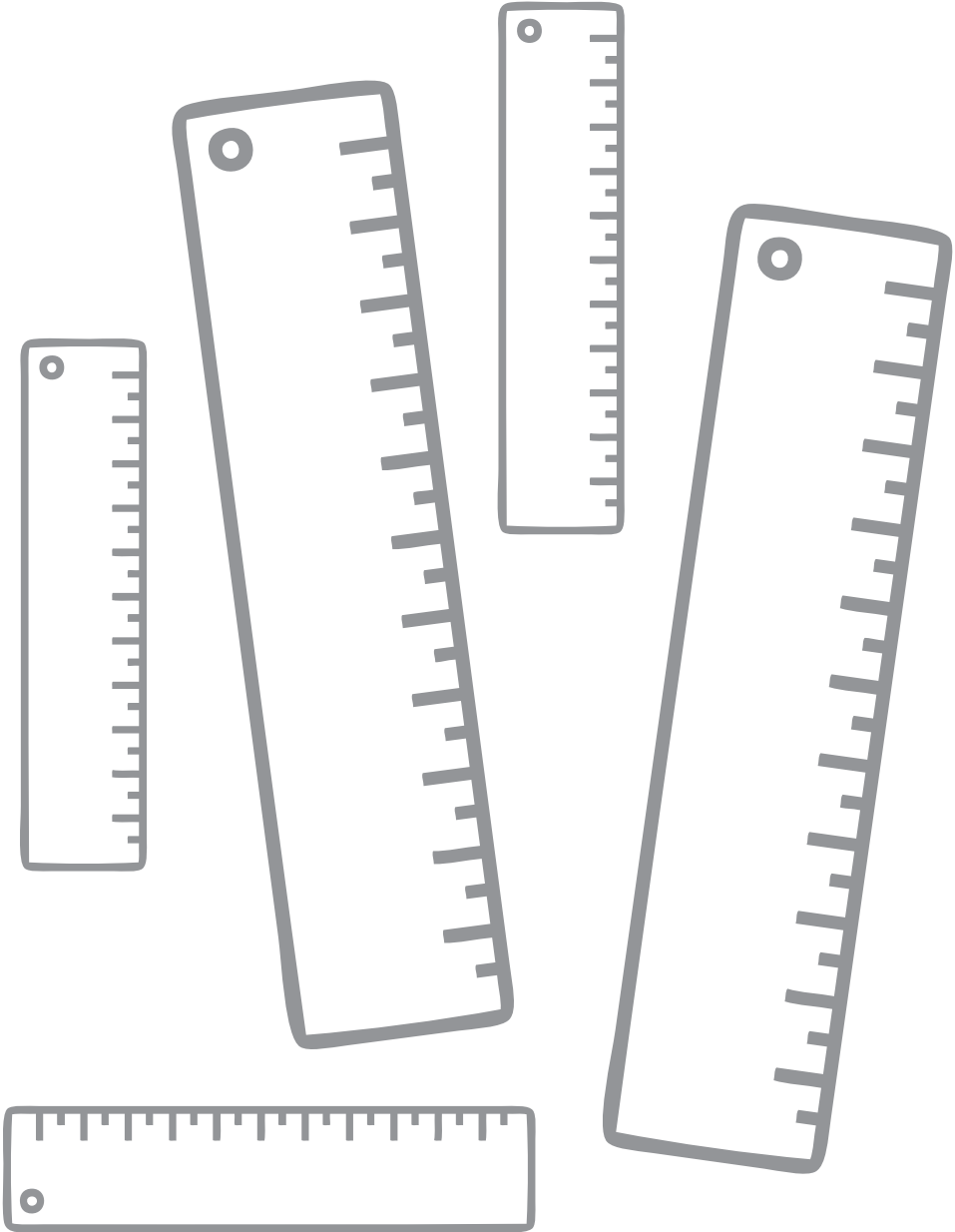

Look at the 50c coin and draw it in the space provided. /  
Kyk na die 50c en teken dit in die spasie.



Week 22

Preprimary

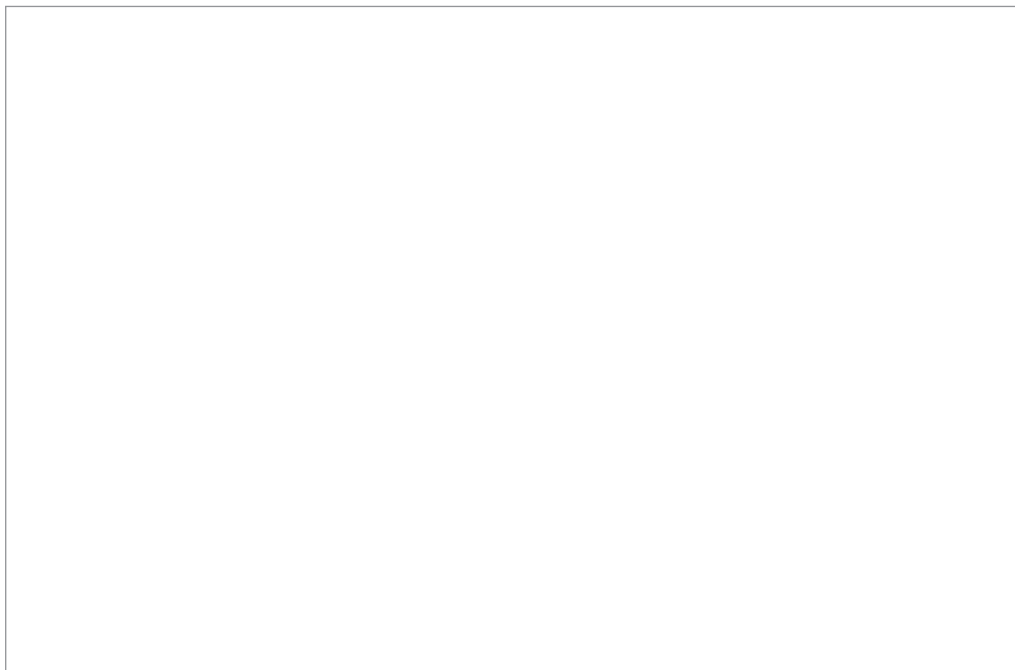

Circle all 5c yellow, 10c with red and 50c with brown. /  
Omkring al die 5c met geel, 10c rooi en 50c bruin.

Week 22

Preprimary



Use any resources available to make a collage. /  
Gebruik enige materiale tot jou beskikking en maak 'n collage.

Week 22

Preprimary

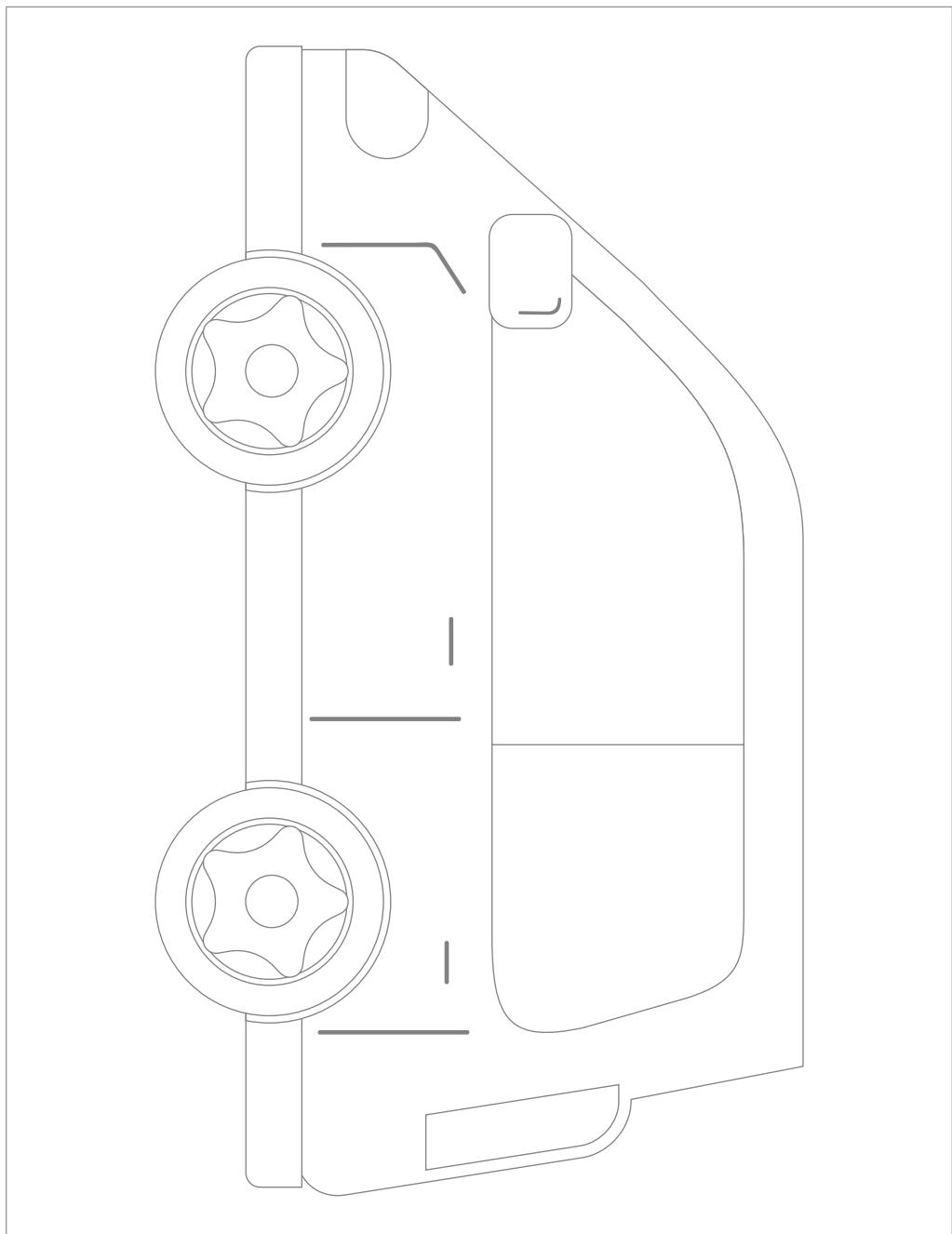



Paint the following picture with a colour of your choice./  
Verf die prent met 'n kleur verf van jou keuse.

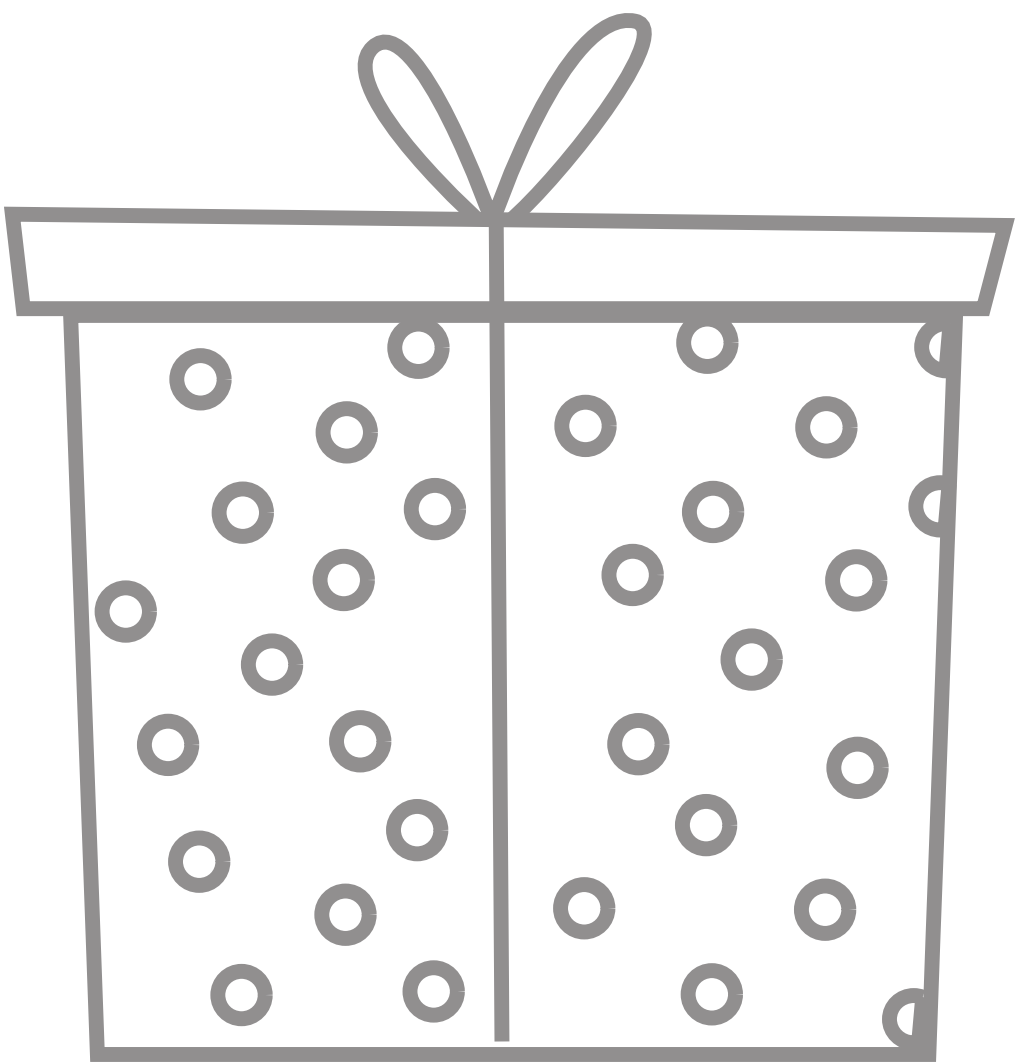

Week 22

Preprimary

Draw your traditional attire. / Teken jou tradisionele drag.

Week 22

Preprimary



Arrange the pictures in a correct sequence. /  
Rangskik die prente in die regte volgorde.

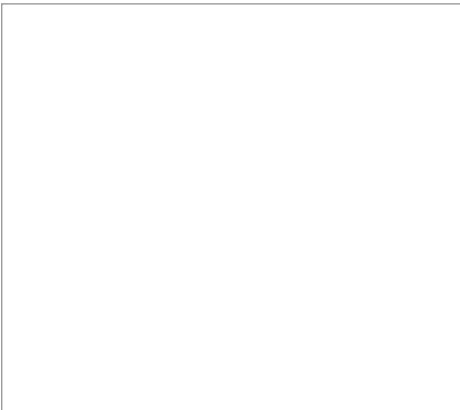
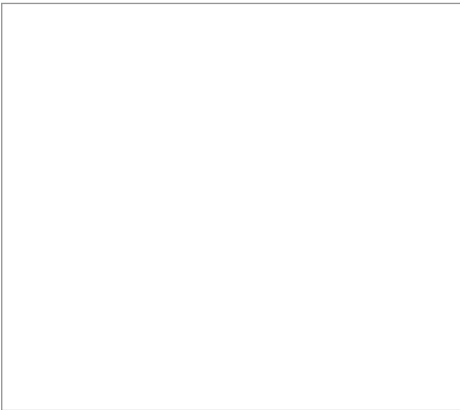

Week 22

Preprimary



Read and colour the flashcards of the different types of food. /  
 Lees en kleur die kaarte van die voedselsoorte kos.

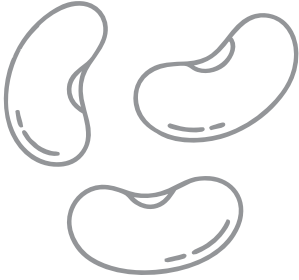

beans / boontjies



porridge / pap

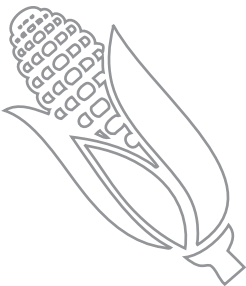

maize / meel



nuts / neute



pumpkin / pampoen

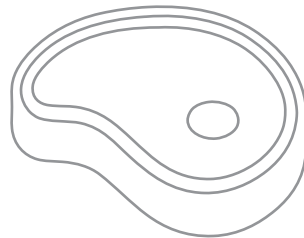

meat / vleis

Week 22

Preprimary

Complete the given patterns. / Voltooi die gegewe patrone.



Week 22



Preprimary



Cut out and complete the puzzle. / Knip uit en voltooi die legkaart.



Week 22

Preprimary





Connect each transport where it's used. /  
Verbind elke vervoer waar dit gebruik word.

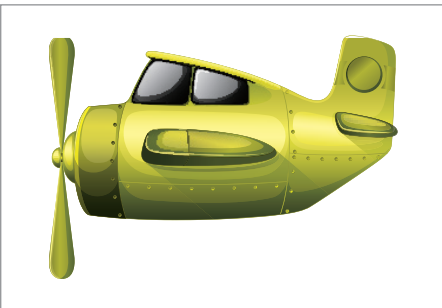
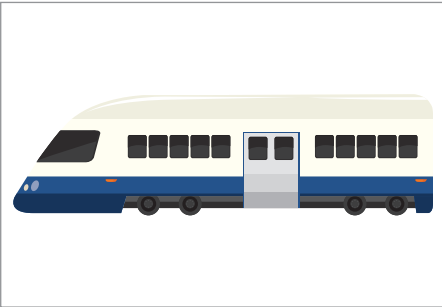

Count the items in each block and write the correct number. /  
Tel die voorwerpe in elke blok and skryf die regte getal.

Week 22

Preprimary



---

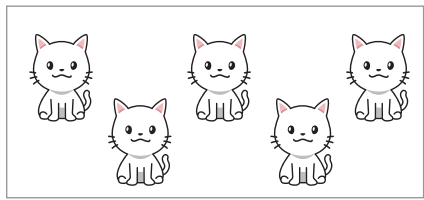

---

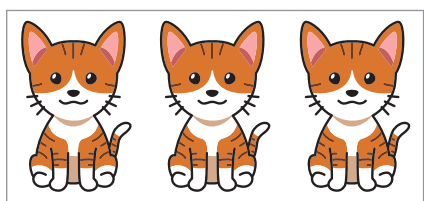

---

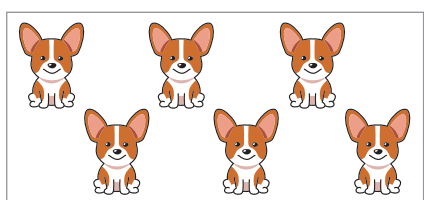

---

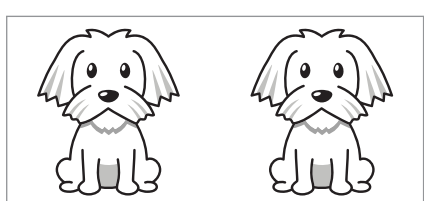

---

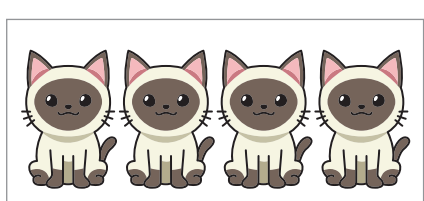

---

# Success begins with education

Parents will be able to visit the website and watch daily videos or they can subscribe to our Zoshy Telegram channel to receive daily videos. One can also download the PDF version of the book on the website. Also watch our daily show on Active Kids to watch your favourite lessons.



<https://t.me/zoshyonline>



For extra perks!



## Register at zoshy

You can save your favourite lessons and find them easier



## Easy peasy steps to follow

- Step 1: Find us at [www.zoshy.online](http://www.zoshy.online) or scan the QR code
- Step 2: Find your grade and select the year
- Step 3: Choose your language
- Step 4: Choose the week you want to learn out of
- Step 5: Choose lessons from what lessons there are
- Step 6: Download booklet if you do not have it
- Step 7: Watch and follow the teacher as she explains what to do in the book
- Step 8: Follow us on Facebook (Zoshy & Active Kids ) to never miss a video
- Step 9: Subscribe to our Zoshy Telegram channel if you want to receive daily updates

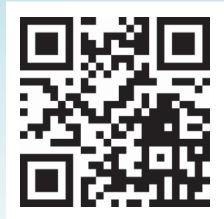

[www.zoshy.online](http://www.zoshy.online)

In collaboration with the Ministry of Education, Arts and Culture

**PRINT**

- 1** Turn the booklet to landscape.
- 2** Take a ruler & tear the booklet at the top long fold.
- 3** Fold the booklet in half.
- 4** The learning journey can start.

**STEPS**  
HOW TO TEAR & USE  
THE BOOKLET



# ROAD SAFETY RULES



## Stop



Always stop  
before crossing  
the road.

## Look



Check both  
ways for cars.

## Listen



Listen to hear  
if any cars are  
close.



**Stop!**  
**Go!**



If there is a traffic  
light always wait  
for the green 'man'  
to light up before  
walking over a road!