

Pre-primary/Preprimêr: Week 17 & 18

5-6 years/ 5-6 jaar

English / Afrikaans

Draw yourself in your school uniform. /
Teken jouself in jou skool uniform.

My School / My Skool

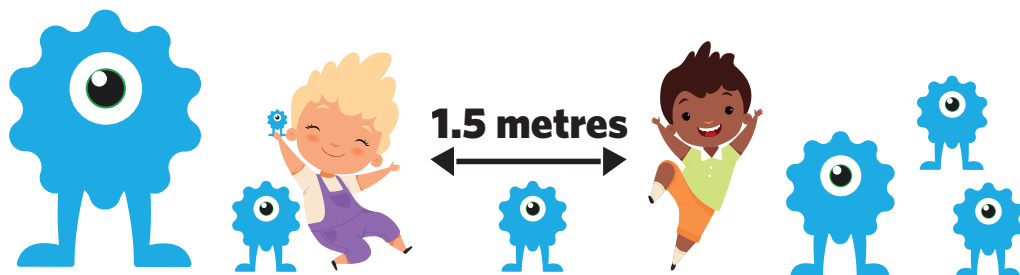

These numbers indicate which day you can complete each worksheet! But if you want to, you can work ahead and do the rest as well.

This publication is a collaboration between the Ministry of Education, Arts and Culture and Namibia Media Holdings. This publication is sponsored by the Ministry.

Copyright © Ministry of Education, Arts and Culture. All parts of this publication cannot be reproduced, stored in a retrieval system or transmitted in any form or by any means, electronic, mechanical, photocopying, recording or otherwise without prior permission of the Ministry of Education, Arts and Culture or the Publisher.

Production by: Namibia Media Holdings **NMH** NAMIBIA MEDIA HOLDINGS

Printing: Newsprint Namibia **newsprint** NAMIBIA

The Ministry of Education, Arts and Culture
www.moe.gov.na



My School / My Skool

Identify names with the same beginning sounds and circle them. /
 Identifiseer name wat met dieselfde klank begin en omkring dit.



Titus



Anna



Tim



Tory

Spot the difference. / Soek die verskille.
Find all the differences and circle them. /
Vind al die verskille en omkring dit.



Week 17

Preprimary



Cut out the pictures and paste them in the correct order. /
Knip die prente uit en plak hulle in die regte volgorde.

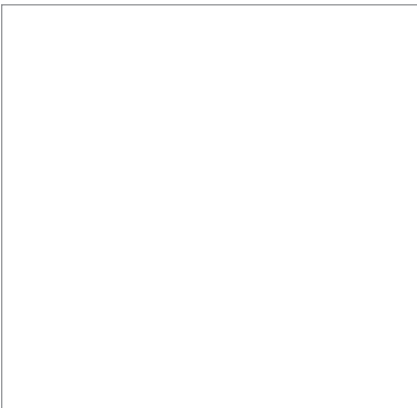
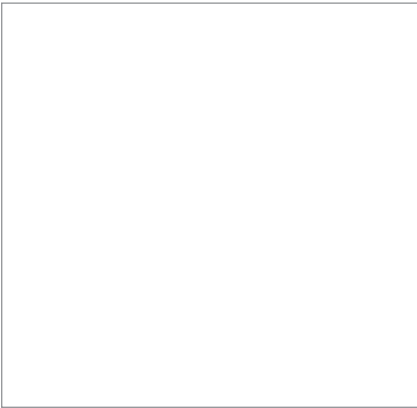
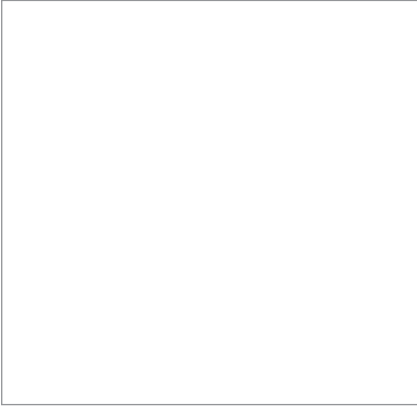

Week 17

Preprimary



Trace the patterns. / Teken die patrone op die stippellyne.

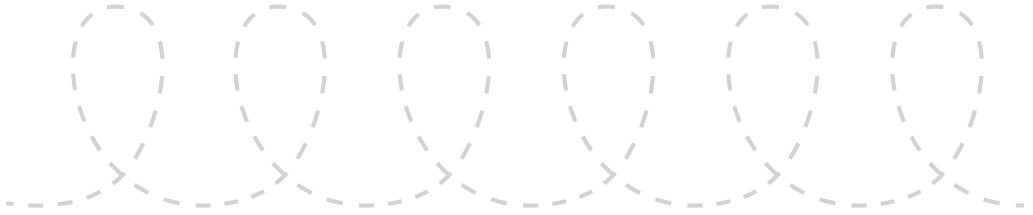

Week 17

Preprimary

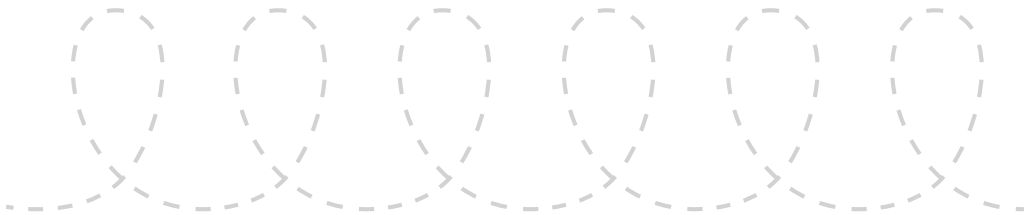

Draw a big circle. Then draw a small square in the circle. /
Teken 'n groot sirkel. Teken dan 'n klein vierkant in die sirkel.

Week 17

Preprimary

Circle anything orange in the picture. /
Omkring enige oranje voorwerpe in die prent.



Week 17

Preprimary

Complete the number pattern. / Voltooi die getalpatrone.

5, 4, 3, 2, 1

5, 4, __, __, __

1, 2, 3, 4, 5

___ / ___ / ___ / ___ / ___

3, 4, 5, __, __

___ / ___ / ___ / ___ / ___



Match the objects with the same length. /
Verbind die items met dieselfde lengte.

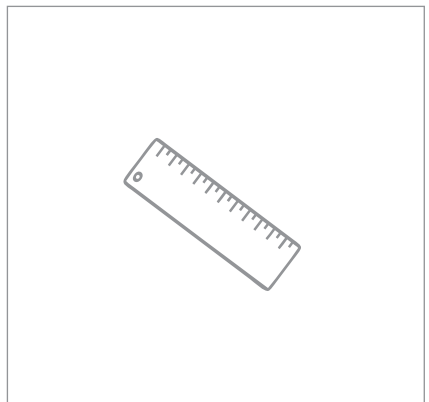
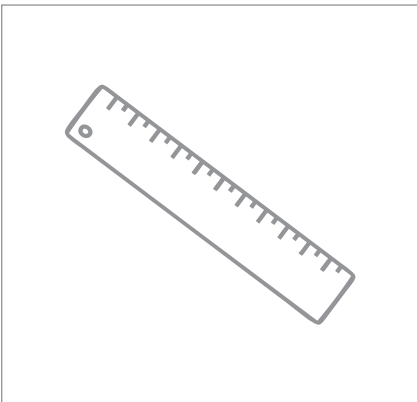
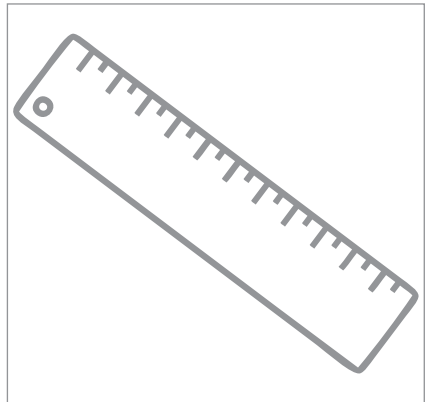
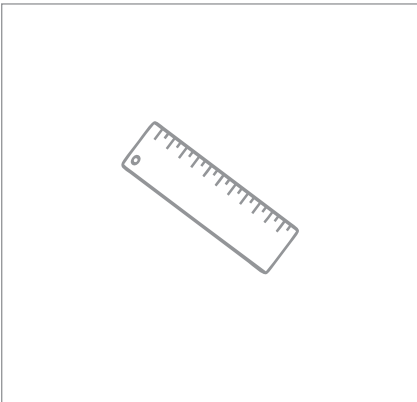
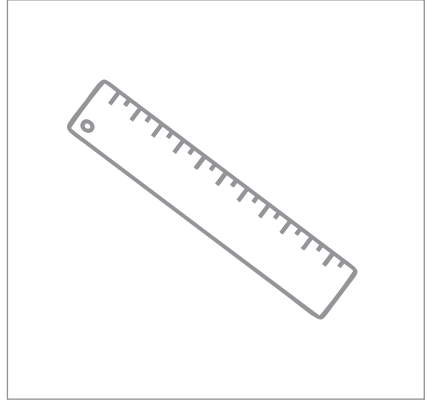
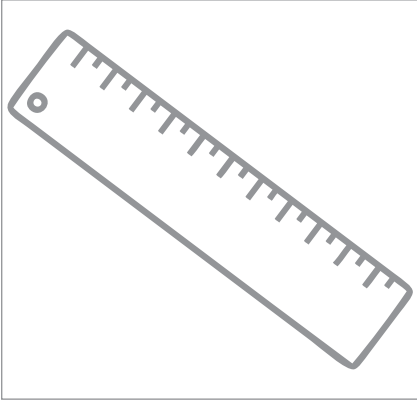

Spot the objects which are near and circle them. /
Soek vir die items wat naby is en omkring dit.

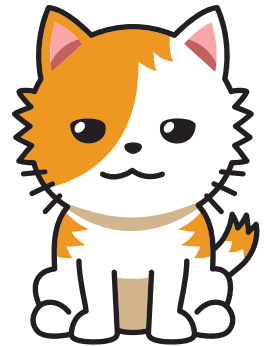
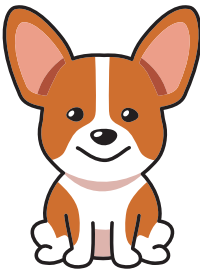
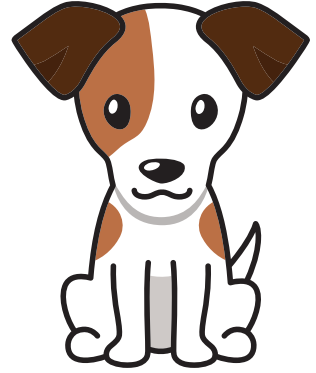
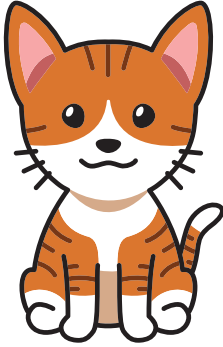

Cut out the glasses and paste them from full to empty. /
Knip die glase uit en plak dit van vol tot leeg.

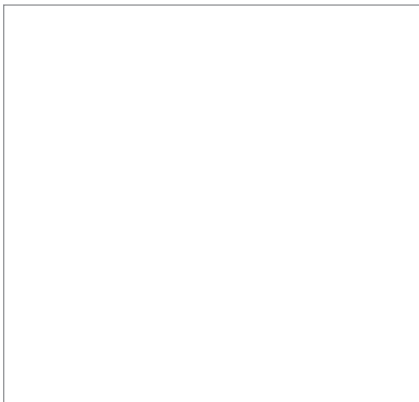
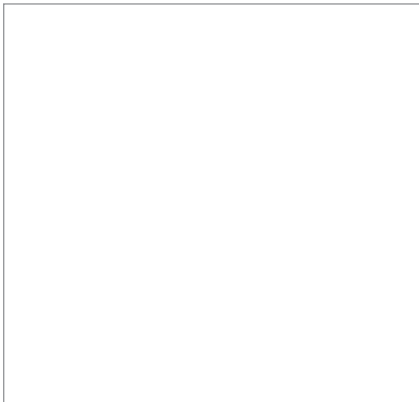

Week 17

Preprimary





Circle all the number 5's. / Omkring al die nommer 5.

2 4 1 3 4
 2 3 5 2 1
 5 4 3 1 4
 2 5 3 2
 1 5 3 1 3
 1 1 4 1 3
 3 4 2 5

Week 17

Preprimary

Trace the dotted triangle. / Teken die driehoek op die stippellyn.

Week 17

Preprimary

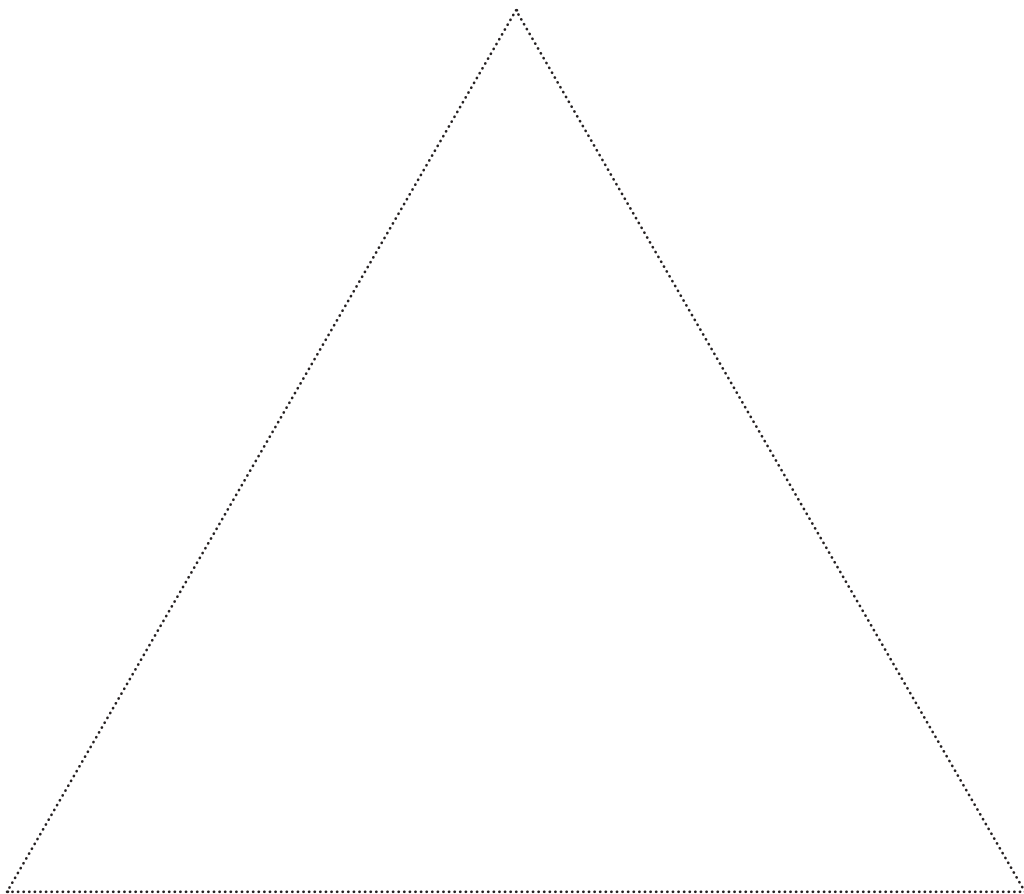

Draw a triangle. / Teken 'n driehoek.

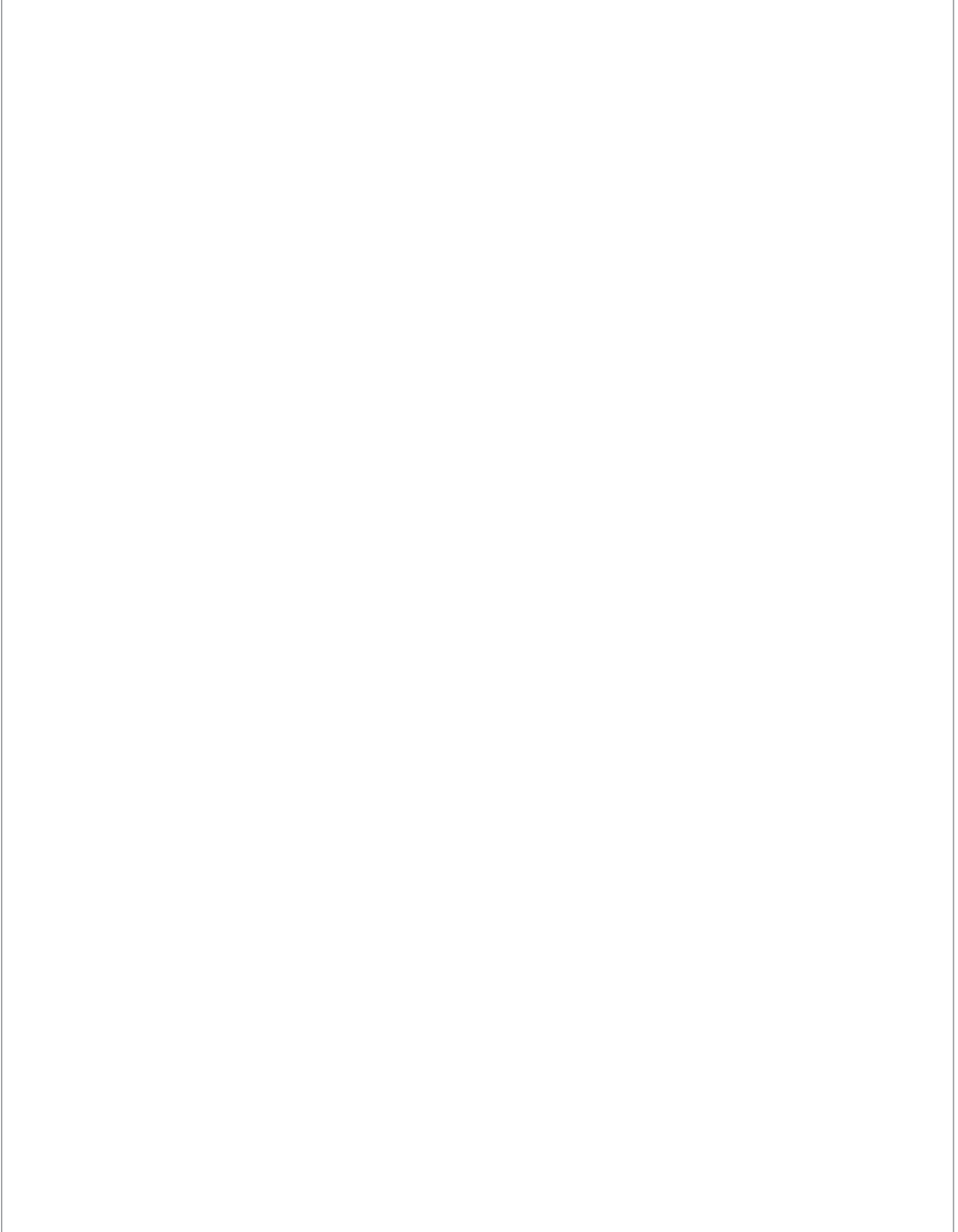

Colour all the triangles with orange, all circles blue
and all squares yellow. /
Kleur al die driehoeke in oranje, al die sirkel blou kleur
en al die vierkante geel.

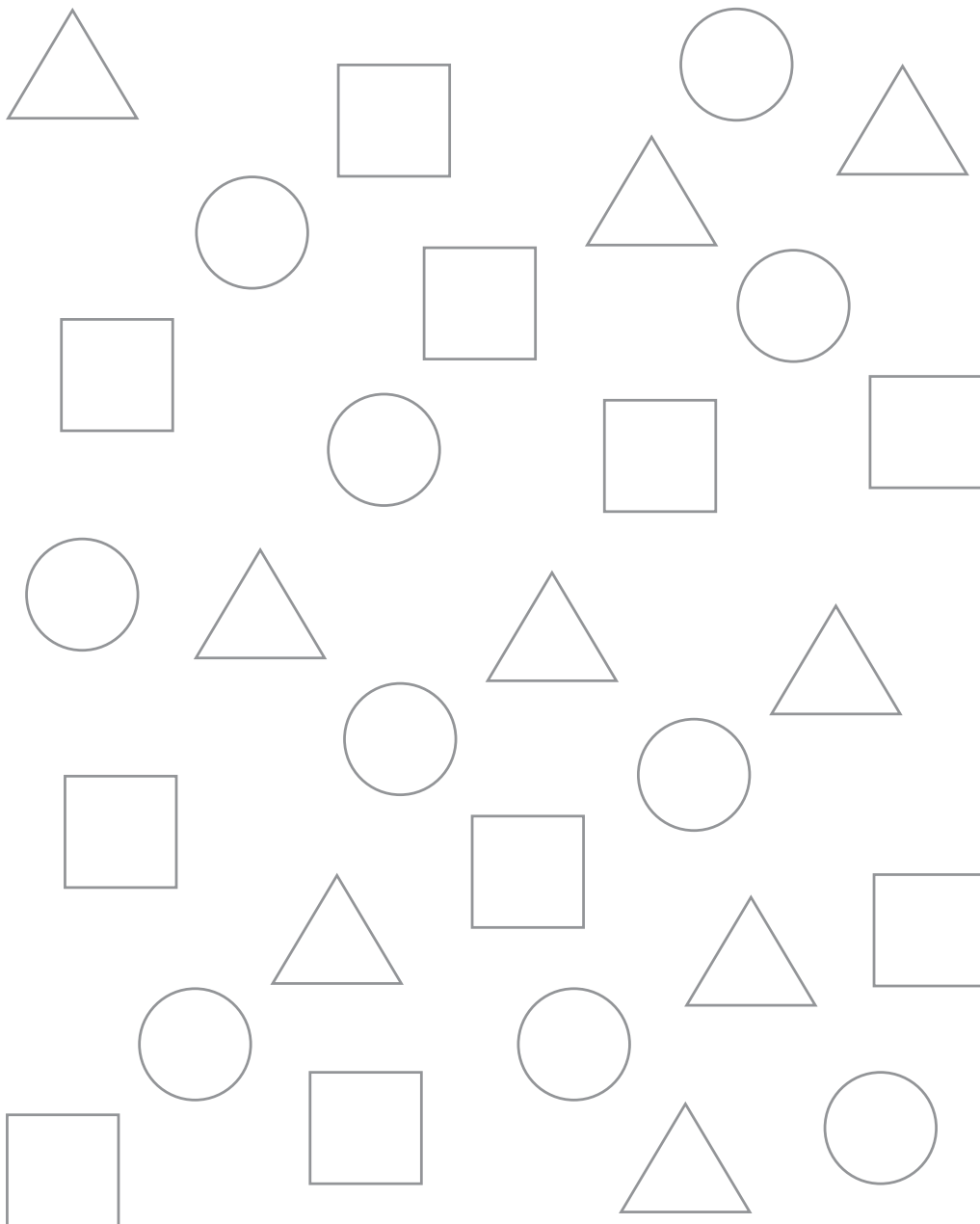

Week 18

Preprimary



Mime what is shown in the picture. /
Mimmeer wat gewys word in die prent.



Week 18

Preprimary

Circle all clothes for cold weather. / Omkring al die klere vir koue weer.

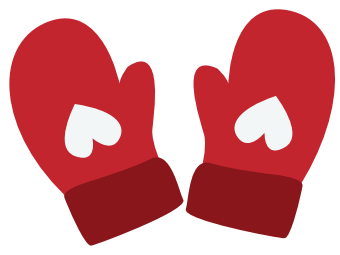
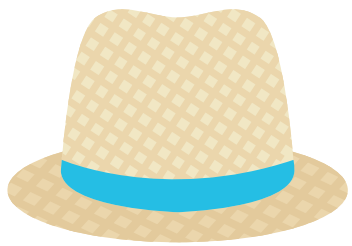
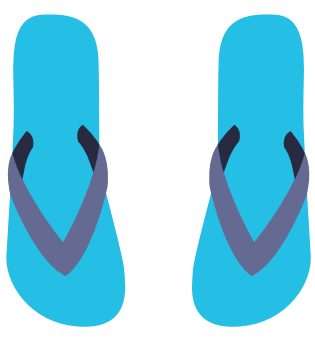
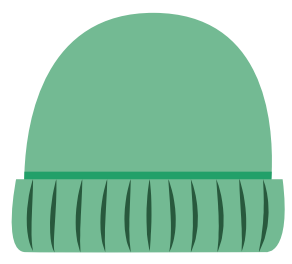

Week 18

Preprimary

Identify with a cross (X) the correct picture where you should cross the road. / Identifiseer met 'n kruis waar om oor die pad te loop.

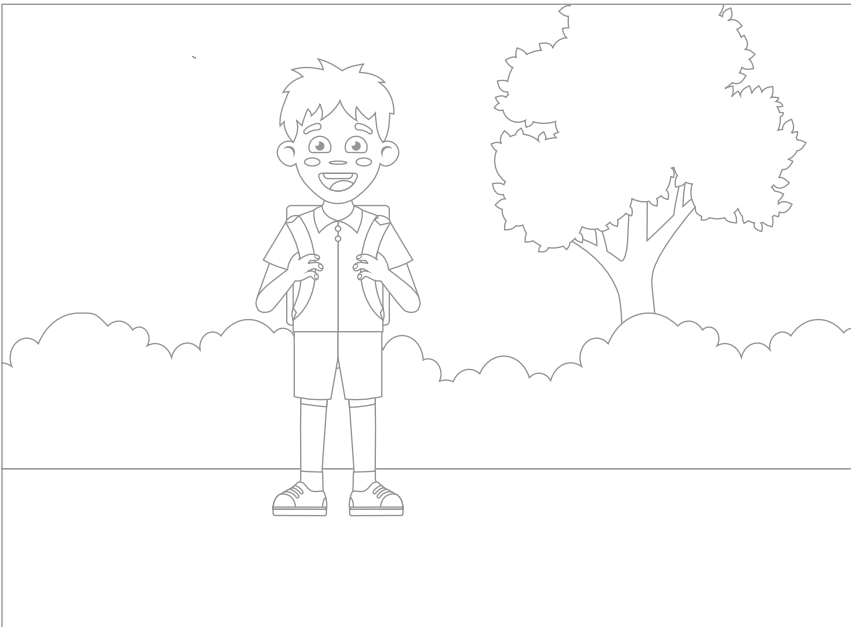
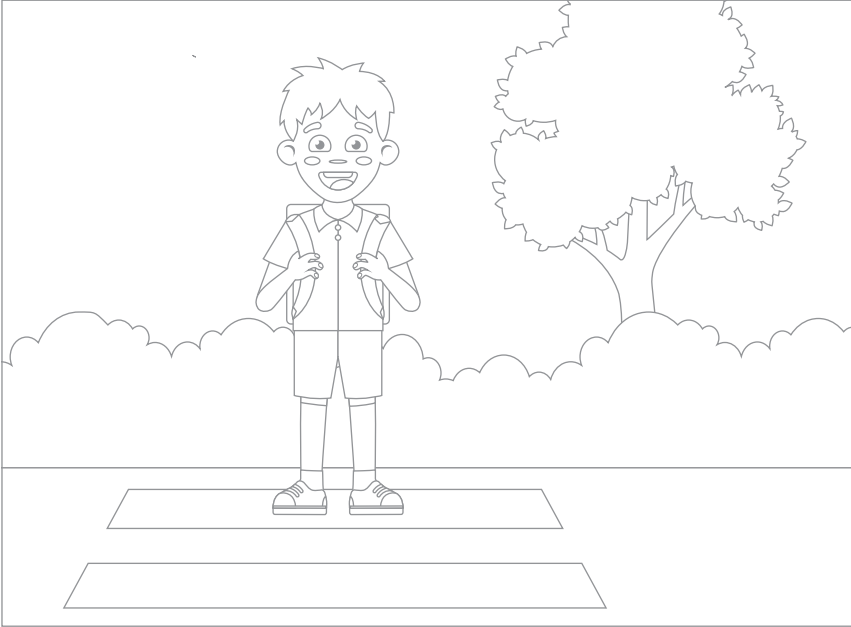

Week 18

Preprimary

Circle all the 10c. / Omkring al die 10c.



Draw any two classroom objects, talk about them with the teacher or parent./ Teken enige twee klaskamer items en praat daaroor met jou onderwyser of ouer.

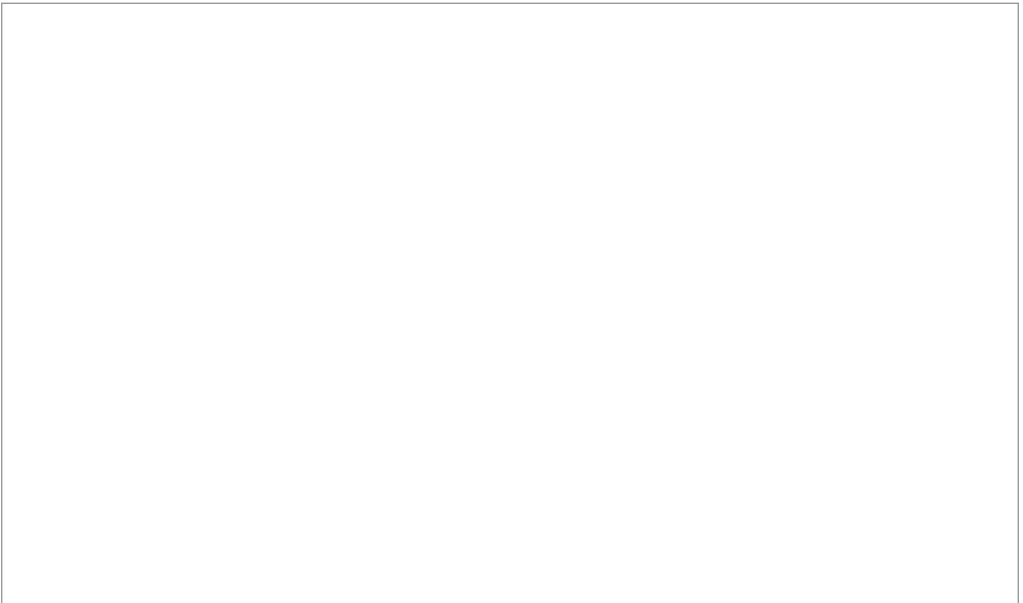

Colour the stop sign with a red crayon./ Kleur die stopteken rooi in.

STOP

Week 18

Preprimary



3

Match the number to the correct set. / Pas die getal by die regte stel.

4



3

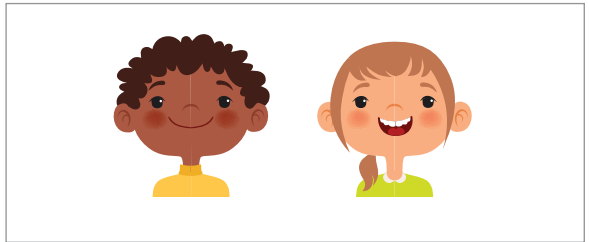

1

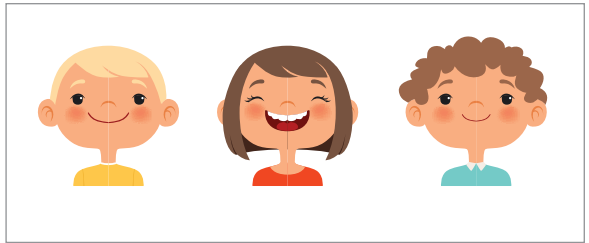

5

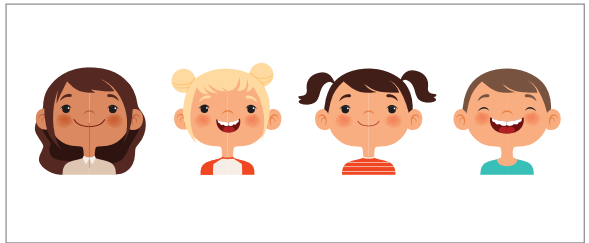

2

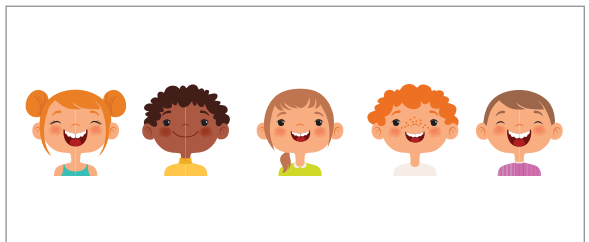

Week 18

Preprimary

Complete the following pattern: / Voltooi die volgende patroon:



Week 18

Preprimary



Cut and paste the objects below on their matching number in the picture. / Knip en plak die voorwerpe onder op die bypassende nommer in die prent.



Week 18

Preprimary





Trace the words and match the word to pictures. /
Teken op die stippellyne en verbind die woorde met die prent.

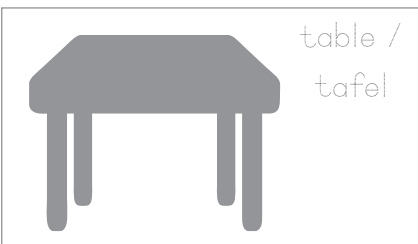
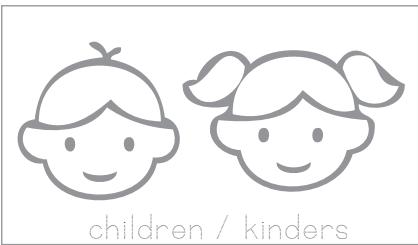
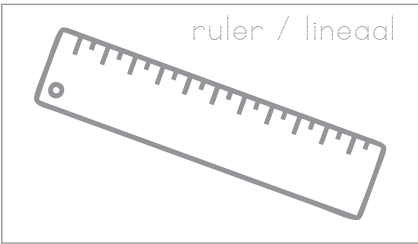
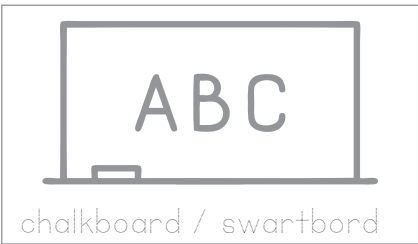

ruler /
lineaal

chalkboard /
swartbord

table /
tafel

chair /
stoel

children /
kinders

Week 18

Preprimary

Count the objects and write the correct number. /
Tel die items en skryf die regte getal.

Week 18

Preprimary

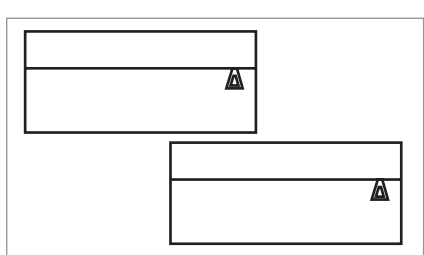
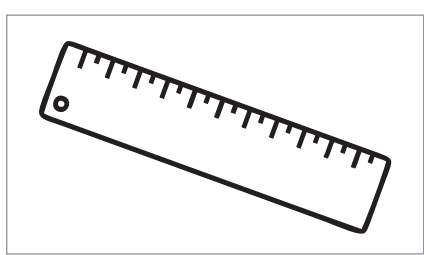
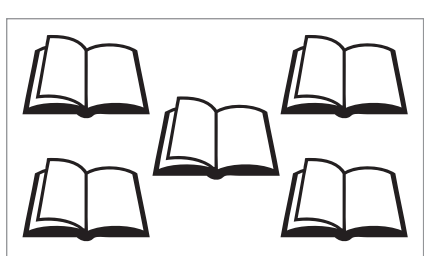
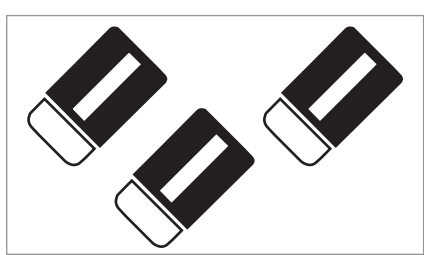
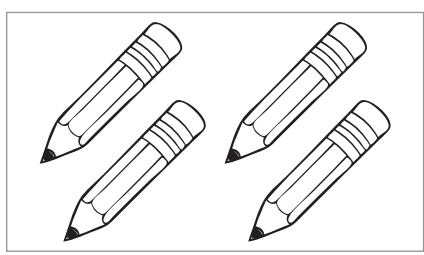

Success begins with education

Parents will be able to visit the website and watch daily videos or they can subscribe to our Zoshy Telegram channel to receive daily videos. One can also download the PDF version of the book on the website. Also watch our daily show on Active Kids to watch your favourite lessons.



<https://t.me/zoshyonline>



For extra perks!

ONLINE

How does it work?



Easy peasy steps to follow

Register at zoshy

You can save your favourite lessons and find them easier



- Step 1: Find us at www.zoshy.online or scan the QR code
- Step 2: Find your grade and select the year
- Step 3: Choose your language
- Step 4: Choose the week you want to learn out of
- Step 5: Choose lessons from what lessons there are
- Step 6: Download booklet if you do not have it
- Step 7: Watch and follow the teacher as she explains what to do in the book
- Step 8: Follow us on Facebook (Zoshy & Active Kids) to never miss a video
- Step 9: Subscribe to our Zoshy Telegram channel if you want to receive daily updates



www.zoshy.online

In collaboration with the Ministry of Education, Arts and Culture

PRINT

1 Turn the booklet to landscape.

2 Take a ruler & tear the booklet at the top long fold.

3 Fold the booklet in half.

4 The learning journey can start.

STEPS
HOW TO TEAR & USE
THE BOOKLET



How to be a HERO

Protect others,
protect yourself



ALL HEROS
WEAR MASKS

